

---

# *Installation Instructions*

---

SERIES 450

## DOORS, SIDELITES AND TRANSOMS

Page 2-3: *Instructions for SINGLE DOORS*

Page 4-5: *Instructions for SINGLE DOORS WITH SIDELITE(s)*

Page 6-7: *Instructions for PAIR OF DOORS*

Page 8-9: *Instructions for PAIR OF DOORS WITH SIDELITE(s)*

Page 10: **Figure 1:** *Frame assembly*

Page 11: **Figure 2:** *Installation screw holes*

**Figure 3:** *Sidelite frame attachment*

**Figure 4:** *Sidelite panel attachment*

**Figure 5:** *Cover location*

Page 12: **Figure 6:** *Installation detail Out-Swing Door Sill*

Page 13: **Figure 7:** *Installation detail Out-Swing Door Head*

Page 14: **Figure 8:** *Installation detail Out-Swing Door Jamb*

Page 15: **Figure 9:** *Transom installation into 1 x 4 bucks*

Page 16: *Trouble Shooting Items to Check*

**NOTE:** Read instructions completely before attempting any installation.

**PRODUCTS ARE SHIPPED FROM FACTORY IN THE FOLLOWING MANNER**

SINGLE DOORS:

*Panel and frame assembled together, covers shipped loose*

PAIR OF DOORS and SIDELITES:

*Frame with covers shipped in box for field assembly Panels shipped separate*

UNITS WITH TRANSOMS:

*Frame pre-assembled at factory. Panel shipped separate.*

*These instructions are provided as a general guide in the installation of our Series 450 products. Applicable Miami-Dade County Product Approvals (or TDI Approvals in Texas) should be used in conjunction with these instructions. Only experienced installers familiar with these or similar products should attempt to install these units. Refer to CGI Series 450 Design Guide for further information & details pertaining to these products and for information on mullions and in-swing door units.*

Technical support is available by contacting CGI at 305-593-6590 (local) or 1-800-442-9042



manufacturer of impact resistant windows and doors

[www.cgiwindows.com](http://www.cgiwindows.com)

## SINGLE DOOR - INSTALLATION INSTRUCTIONS

1. Remove door panel from frame by removing hinge pins or removing hinges completely.
2. Measure out to out of assembled frame and make sure that frame will fit opening. Also, check that opening is square and plumb. Remember that opening must have pressure treated wood bucks (either 1x4 or 2x4, see *figures 6-8*) on top and sides. These bucks must be fully set in sealant. If using 2x bucks, bucks must be independently secured to concrete with concrete anchors.
3. Position door frame into opening and shim on all sides as required (note: frames for pairs are reversible, frames for single doors are not). Pre-install frame using installation screws/anchors (not supplied by CGI). Refer to CGI door product approvals for required screws/anchors and possible extra screw/anchors required at Meeting Stiles based on project loads; refer to *figure 2* (and *figure 9* if a transom panel is being used). Make sure to shim frame at all installation screw/anchor points.
4. Install door panels on frames and attach levers (located below deadbolt) on latch housing.
5. Check that door closes smoothly and correctly. Be careful not to damage weatherstripping if door is not closing properly. Verify that frame is not racked and causing door to close unevenly. Uniform separation should exist between door and frame on all sides. Some frame adjustments may be required during this step to assure proper operation. Adjust frame position and add or remove shims as needed.
6. Tighten all installation screws/anchors and install any missing screws/anchors. Seal all screws/anchors at sill of door. Seal gap at both ends between sill channel (where installation screws sit) and frame jamb (see *item 3* on *figure 1*).
7. Apply professional grade sealant between door frame and wood bucks at top & sides and between door frame and concrete at sill.
8. Drive hinge pins completely into hinges and tighten set screw located on hinge stem (door must be opened to access this set screw).
9. If this unit has an integral Series 450 transom panel (not a separate transom window such as a Designer Fixed Window), you can install this panel at this stage. Note that installing the transom panel will hide the installation screws at the head (consult with your building inspector). You may decide to hold off on the transom panel installation until the opening has been inspected or you can install this panel now and remove it when inspection is being made. To install the panel, refer to *figure 9*. Panel should be installed from the exterior by inserting top of panel into head channel (pre-installed at CGI) and swing the bottom of the panel towards the frame. The panel should be secured to the transom frame mullion using #10 x 1" stainless steel screws (supplied by CGI).



10. If this door is being installed in a new project still under construction, continue on to step 11 below. If this door is being installed in a replacement job, continue on to step 13.
11. At this point you may want to remove the levers installed on step 5 until project is closer to final completion. If not removing, levers should be wrapped and protected during construction.
12. Wrap and protect the deadbolt, hinges and threshold. Do not remove deadbolt as this is connected to CGI's patented three point lock mechanism, which is adjusted in the factory.
13. In order to clearly see the installation screws/anchors, installation of jamb covers and head & sill covers may need to be delayed until job is inspected, consult your building inspector. Once inspected (refer to *figure 5*), install covers. Note that the head & sill covers may require slight filing of holes where flush bolts and three point locks engage. **It is imperative that the installer makes sure that the three point locks are properly engaging into the head and sill covers. Failure to do so may cause the door to fail during a storm or hurricane.** Refer to items 9. and 10. of the Trouble Shooting portion at the end of this instruction manual. Also, be sure to install head & sill covers on single doors with hole towards lock side.
14. CGI assumes no responsibility for keying of locks. User should consider having a locksmith change all key combinations.



## SINGLE DOOR WITH SIDELITE(s) - INSTALLATION INSTRUCTIONS

1. Remove door panel from frame by removing hinge pins or removing hinges completely.
2. Build sidelite frame as shown on *figure 1*. To build frame:
  - a. Apply silicone sealant to ends of head and sill members as shown on *item 1*.
  - b. Attach head and sill member by inserting #12 x 1 1/4" hex head SMS (supplied) into pre-drilled assembly holes. Use three screws per connection as shown on *item 2*.
  - c. Since pre-drilled holes are slightly oversized, some rotation may occur when assembling. Make sure all connections are square and have not rotated.
  - d. Tighten all screws.
3. Attach sidelite frame(s) and door frame as shown on *figure 3*. Apply continuous silicone sealant at exterior joint, attach vertical sidelite adapter jamb to door jamb and secure using # 14 x 3/4" hex head S/S TEK screws as shown.
4. Measure out to out of assembled frame and make sure that frame will fit opening. Also, check that opening is square and plumb. Remember that opening must have pressure treated wood bucks (either 1x4 or 2x4, see *figures 6-8*) on top and sides. These bucks must be fully set in sealant. If using 2x bucks, bucks must be independently secured to concrete with concrete anchors.
5. Position door frame into opening and shim on all sides as required (note: frames for pairs are reversible, frames for single doors are not). Pre-install frame using installation screws/anchors (not supplied by CGI). Refer to CGI door product approvals for required screws/anchors and possible extra screw/anchors required at Meeting Stiles based on project loads; refer to *figure 2* (and *figure 9* if a transom panel is being used). Make sure to shim frame at all installation screw/anchor points.
6. Install door panels on frames and attach levers (located below deadbolt) on latch housing.
7. Check that door closes smoothly and correctly. Be careful not to damage weatherstripping if door is not closing properly. Verify that frame is not racked and causing door to close unevenly. Uniform separation should exist between door and frame on all sides. Some frame adjustments may be required during this step to assure proper operation. Adjust frame position and add or remove shims as needed.
8. Tighten all installation screws/anchors and install any missing screws/anchors. Seal all screws/anchors at sill of door. Seal gap at both ends between sill channel (where installation screws sit) and frame jamb (see *item 3* on *figure 1*).
9. Apply professional grade sealant between door frame and wood bucks at top & sides and between door frame and concrete at sill.
10. Drive hinge pins completely into hinges and tighten set screw located on hinge stem (door must be opened to access this set screw).



11. <sup>①</sup> Install head and sill covers at sidelite frame (see *figure 5*) and then install sidelite panel using # 10 x 1" pan head S/S TEK screws at 3" & 7" from ends and 24" on center max, refer to *figure 4*. Screws are only required at vertical connections (both sides), not at head or sill.
12. If this unit has an integral Series 450 transom panel (not a separate transom window such as a Designer Fixed Window), you can install this panel at this stage. Note that installing the transom panel will hide the installation screws at the head (consult with your building inspector). You may decide to hold off on the transom panel installation until the opening has been inspected or you can install this panel now and remove it when inspection is being made. To install the panel, refer to *figure 9*. Panel should be installed from the exterior by inserting top of panel into head channel (pre-installed at CGI) and swing the bottom of the panel towards the frame. The panel should be secured to the transom frame mullion using #10 x 1" stainless steel screws (supplied by CGI).
13. If this door is being installed in a new project still under construction, continue on to step 14 below, if this door is being installed in a replacement job, continue on to step 16.
14. At this point you may want to remove the levers installed on step 6 until project is closer to final completion. If not removing, levers should be wrapped and protected during construction.
15. Wrap and protect the deadbolt, hinges and threshold. Do not remove deadbolt as this is connected to CGI's patented three point lock mechanism, which is adjusted in the factory.
16. <sup>②</sup> Install remaining covers; refer to *figure 5* for location. Note that the head & sill covers may require slight filing of holes where flush bolts and three point locks engage. **It is imperative that the installer makes sure that the three point locks are properly engaging into the head and sill covers. Failure to do so may cause the door to fail during a storm or hurricane.** Refer to items 9. and 10. of the Trouble Shooting portion at the end of this instruction manual. Also, be sure to install head & sill covers on single doors with hole towards lock side.
17. CGI assumes no responsibility for keying of locks. User should consider having a locksmith change all key combinations.

---

<sup>①</sup> This step will conceal the head and sill installation screws at sidelites.

<sup>②</sup> This step will conceal the remaining installation screws.

**An inspection may be required prior to these steps (①&②), consult building inspector.**



## PAIR OF DOORS - INSTALLATION INSTRUCTIONS

1. Build door frame prior to installing in opening as shown on *figure 1*. To build frame:
  - a. Apply silicone sealant to ends of head and sill members as shown on *item 1*.
  - b. Attach head and sill member by inserting #12 x 1 ¼” hex head SMS (supplied) into pre-drilled assembly holes. Use three screws per connection as shown on *item 2*.
  - c. Since pre-drilled holes are slightly oversized, some rotation may occur when assembling. Make sure all connections are square and have not rotated.
  - d. Tighten all screws.
2. Measure out to out of assembled frame and make sure that frame will fit opening. Also, check that opening is square and plumb. Remember that opening must have pressure treated wood bucks (either 1x4 or 2x4, see *figures 6-8*) on top and sides. These bucks must be fully set in sealant. If using 2x bucks, bucks must be independently secured to concrete with concrete anchors.
3. Position door frame into opening and shim on all sides as required (note: frames for pairs are reversible, frames for single doors are not). Pre-install frame using installation screws/anchors (not supplied by CGI). Refer to CGI door product approvals for required screws/anchors and possible extra screw/anchors required at Meeting Stiles based on project loads; refer to *figure 2* (and *figure 9* if a transom panel is being used). Make sure to shim frame at all installation screw/anchor points.
4. Install door panels on frames and attach levers (located below deadbolt) on latch housing.
5. Check that door closes smoothly and correctly. Be careful not to damage weatherstripping if door is not closing properly. Verify that frame is not racked and causing door to close unevenly. Uniform separation should exist between door and frame on all sides. Some frame adjustments may be required during this step to assure proper operation. Adjust frame position and add or remove shims as needed.
6. Tighten all installation screws/anchors and install any missing screws/anchors. Seal all screws/anchors at sill of door. Seal gap at both ends between sill channel (where installation screws sit) and frame jamb (see *item 3* on *figure 1*).
7. Apply professional grade sealant between door frame and wood bucks at top & sides and between door frame and concrete at sill.
8. Drive hinge pins completely into hinges and tighten set screw located on hinge stem (door must be opened to access this set screw).
9. If this unit has an integral Series 450 transom panel (not a separate transom window such as a Designer Fixed Window), you can install this panel at this stage. Note that installing the transom panel will hide the installation screws at the head (consult with your building inspector). You may decide to hold off on the transom panel installation until the opening has been inspected or you can install this panel now and remove it



when inspection is being made. To install the panel, refer to *figure 9*. Panel should be installed from the exterior by inserting top of panel into head channel (pre-installed at CGI) and swing the bottom of the panel towards the frame. The panel should be secured to the transom frame mullion using #10 x 1" stainless steel screws (supplied by CGI).

10. If this door is being installed in a new project still under construction, continue on to step 11 below, if this door is being installed in a replacement job, continue on to step 13.
11. At this point you may want to remove the levers installed on step 5 until project is closer to final completion. If not removing, levers should be wrapped and protected during construction.
12. Wrap and protect the deadbolt, hinges and threshold. Do not remove deadbolt as this is connected to CGI's patented three point lock mechanism, which is adjusted in the factory.
13. In order to clearly see the installation screws/anchors, installation of jamb covers and head & sill covers may need to be delayed until job is inspected, consult your building inspector. Once inspected, refer to *figure 5* for location of these covers. Note that the head & sill covers may require slight filing of holes where flush bolts and three point locks engage. **It is imperative that the installer makes sure that the three point locks are properly engaging into the head and sill covers. Failure to do so may cause the door to fail during a storm or hurricane.** Refer to items 9. and 10. of the Trouble Shooting portion at the end of this instruction manual.
14. CGI assumes no responsibility for keying of locks. User should consider having a locksmith change all key combinations.



## **PAIR OF DOORS WITH SIDELITE(s) - INSTALLATION INSTRUCTIONS**

1. Build door frame prior to installing in opening as shown on *figure 1*. To build frame:
  - a. Apply silicone sealant to ends of head and sill members as shown on *item 1*.
  - b. Attach head and sill member by inserting #12 x 1 ¼” hex head SMS (supplied) into pre-drilled assembly holes. Use three screws per connection as shown on *item 2*.
  - c. Since pre-drilled holes are slightly oversized, some rotation may occur when assembling. Make sure all connections are square and have not rotated.
  - d. Tighten all screws.
2. Repeat steps a. through d. above for sidelite frame(s).
3. Attach sidelite frame(s) and door frame as shown on *figure 3*. Apply continuous silicone sealant at exterior joint, attach vertical sidelite adapter jamb to door jamb and secure using # 14 x ¾” hex head S/S TEK screws as shown.
4. Measure out to out of assembled frame and make sure that frame will fit opening. Also, check that opening is square and plumb. Remember that opening must have pressure treated wood bucks (either 1x4 or 2x4, see *figures 6-8*) on top and sides. These bucks must be fully set in sealant. If using 2x bucks, bucks must be independently secured to concrete with concrete anchors.
5. Position door frame into opening and shim on all sides as required (note: frames for pairs are reversible, frames for single doors are not). Pre-install frame using installation screws/anchors (not supplied by CGI). Refer to CGI door product approvals for required screws/anchors and possible extra screw/anchors required at Meeting Stiles based on project loads; refer to *figure 2* (and *figure 9* if a transom panel is being used). Make sure to shim frame at all installation screw/anchor points.
6. Install door panels on frames and attach levers (located below deadbolt) on latch housing.
7. Check that door closes smoothly and correctly. Be careful not to damage weatherstripping if door is not closing properly. Verify that frame is not racked and causing door to close unevenly. Uniform separation should exist between door and frame on all sides. Some frame adjustments may be required during this step to assure proper operation. Adjust frame position and add or remove shims as needed.
8. Tighten all installation screws/anchors and install any missing screws/anchors. Seal all screws/anchors at sill of door. Seal gap at both ends between sill channel (where installation screws sit) and frame jamb (see *item 3* on *figure 1*).
9. Apply professional grade sealant between door frame and wood bucks at top & sides and between door frame and concrete at sill.
10. Drive hinge pins completely into hinges and tighten set screw located on hinge stem (door must be opened to access this set screw).



11. If this unit has an integral Series 450 transom panel (not a separate transom window such as a Designer Fixed Window), you can install this panel at this stage. Note that installing the transom panel will hide the installation screws at the head (consult with your building inspector). You may decide to hold off on the transom panel installation until the opening has been inspected or you can install this panel now and remove it when inspection is being made. To install the panel, refer to *figure 9*. Panel should be installed from the exterior by inserting top of panel into head channel (pre-installed at CGI) and swing the bottom of the panel towards the frame. The panel should be secured to the transom frame mullion using #10 x 1" stainless steel screws (supplied by CGI).
12. <sup>①</sup> Install head and sill covers at sidelite frame (see *figure 5*) and then install sidelite panel using # 10 x 1" pan head S/S TEK screws at 3" & 7" from ends and 24" on center max, refer to *figure 4*. Screws are only required at vertical connections (both sides), not at head or sill.
13. If this door is being installed in a new project still under construction, continue on to step 14 below, if this door is being installed in a replacement job, continue on to step 16.
14. At this point you may want to remove the levers installed on step 6 until project is closer to final completion. If not removing, levers should be wrapped and protected during construction.
15. Wrap and protect the deadbolt, hinges and threshold. Do not remove deadbolt as this is connected to CGI's patented three point lock mechanism, which is adjusted in the factory.
16. <sup>②</sup> Install remaining covers; refer to *figure 5* for location. Note that the head & sill covers may require slight filing of holes where flush bolts and three point locks engage. **It is imperative that the installer makes sure that the three point locks are properly engaging into the head and sill covers. Failure to do so may cause the door to fail during a storm or hurricane.** Refer to items 9. and 10. of the Trouble Shooting portion at the end of this instruction manual. Also, be sure to install head & sill covers on single doors with hole towards lock side.
17. CGI assumes no responsibility for keying of locks. User should consider having a locksmith change all key combinations.

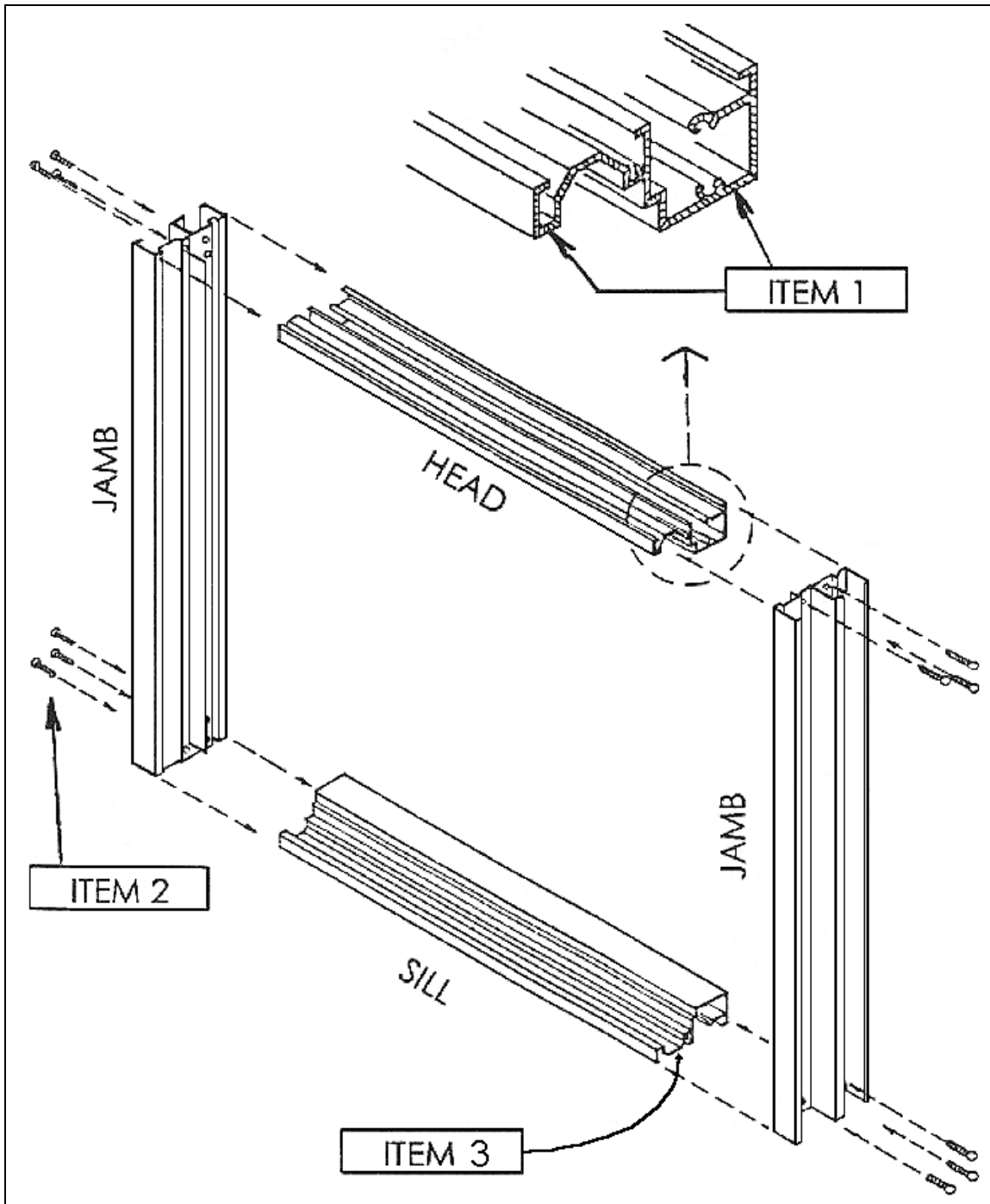
---

<sup>①</sup> This step will conceal the head and sill installation screws at sidelites.

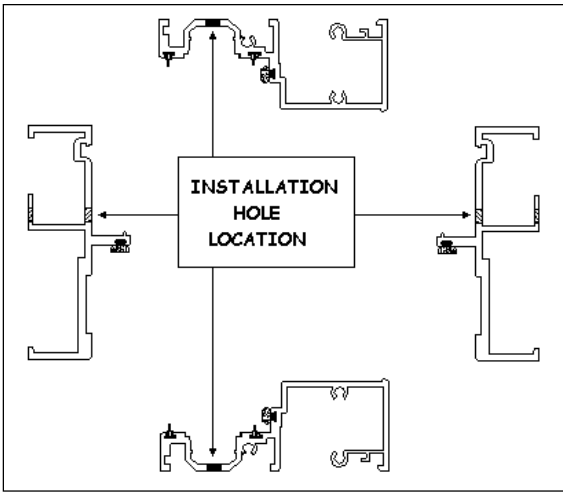
<sup>②</sup> This step will conceal the remaining installation screws.

**An inspection may be required prior to these steps (①&②), consult building inspector.**

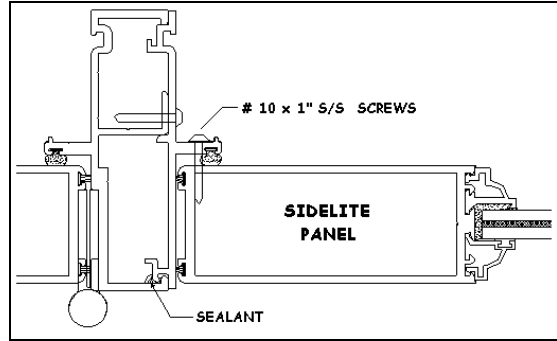




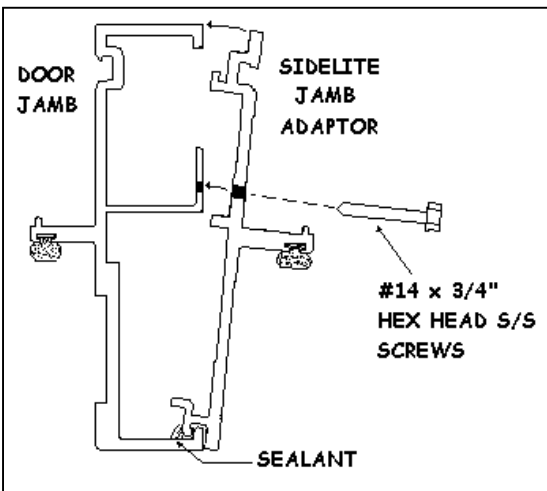
**Figure 1:** Frame assembly.



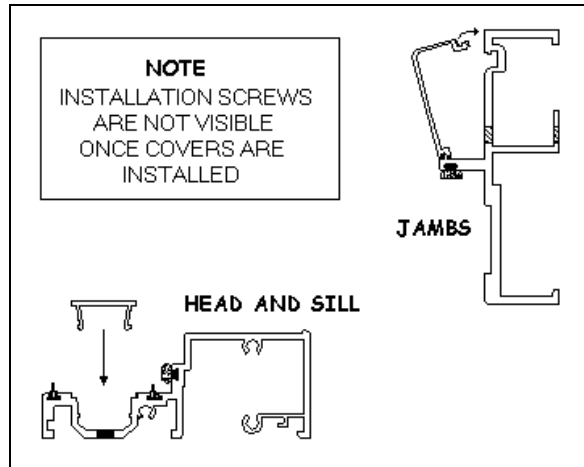
**Figure 2:** Installation screw holes.



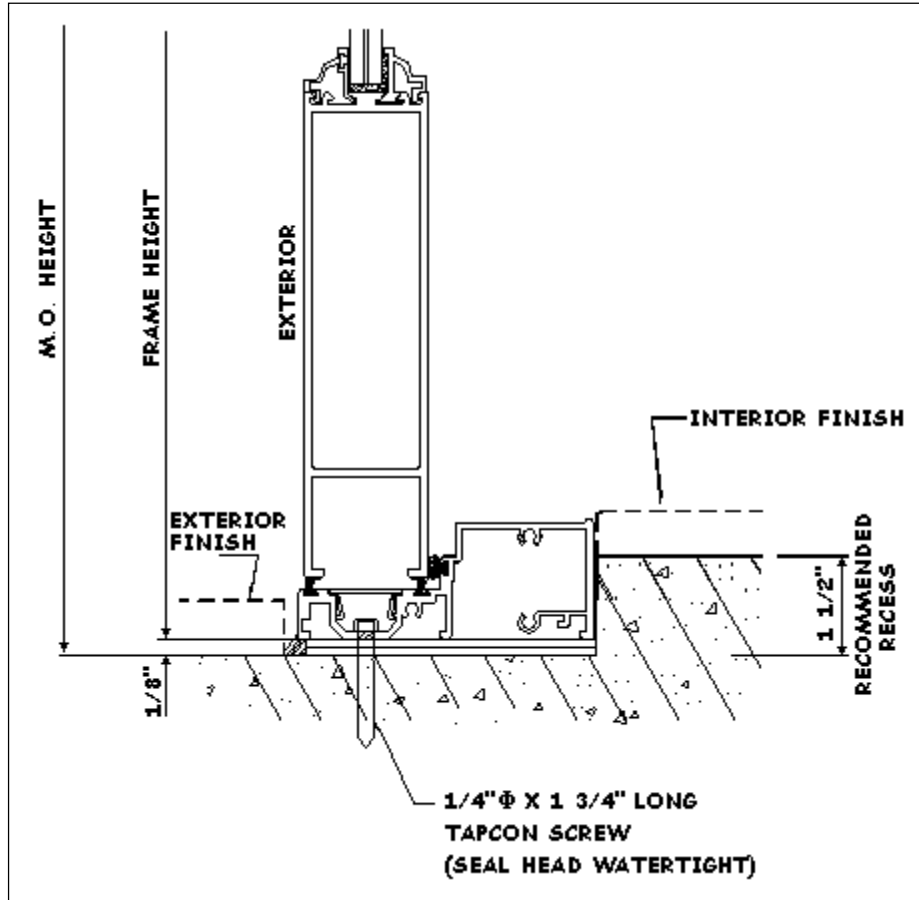
**Figure 4:** Sidelite panel attachment.



**Figure 3:** Sidelite frame attachment.



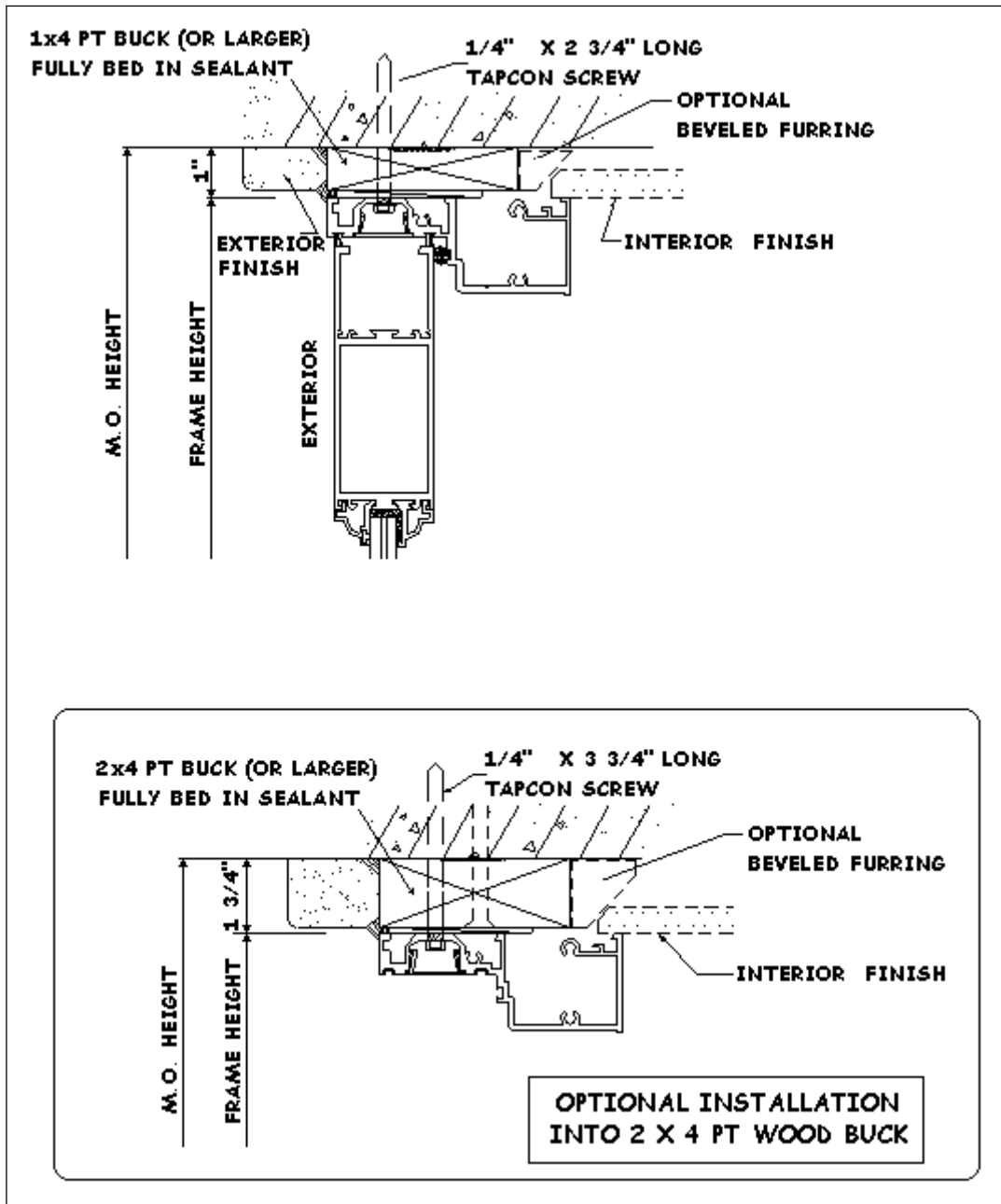
**Figure 5:** cover location.



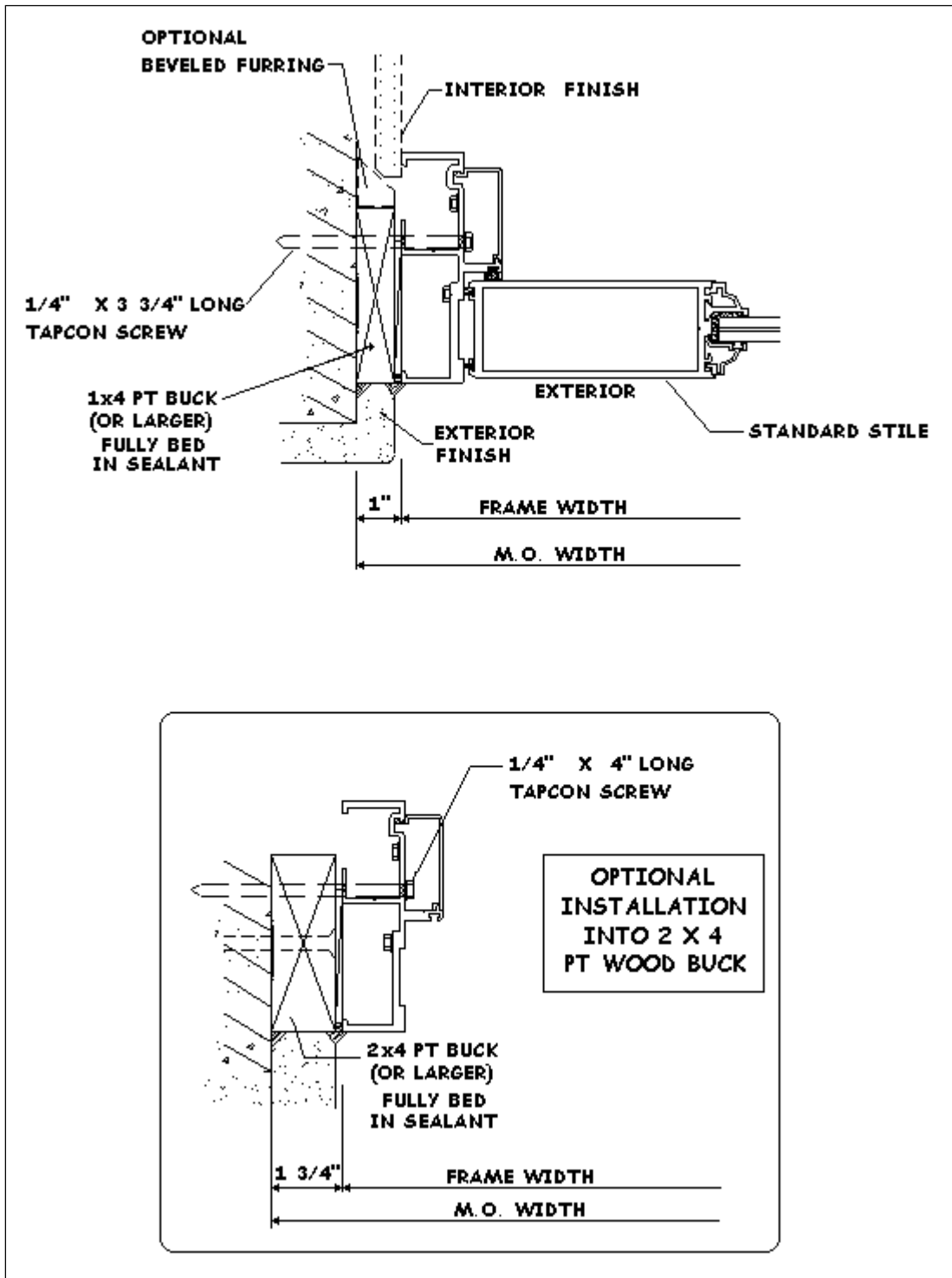
Figure

Installation detail Out-Swing Door Sill.

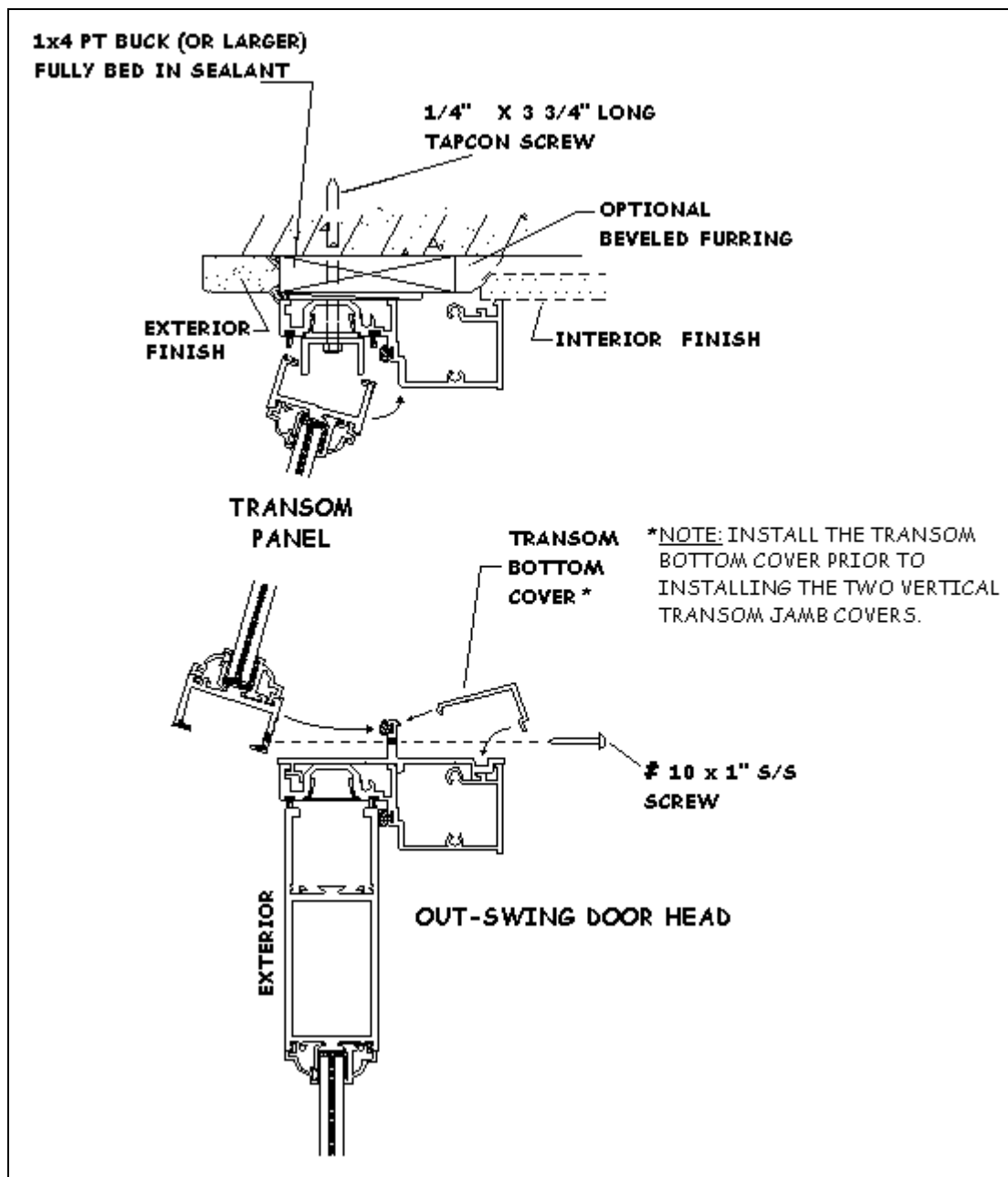
6:



**Figure 7:** Installation detail Out-Swing Door Head.



**Figure 8:** Installation detail Out-Swing Door Jamb.  
(Sidelite Jamb is similar)



**Figure 9:** Transom installation into 1 x 4 bucks.

## **Trouble Shooting Items to Check for Series 450 Doors and Sidelites with Residential Hardware**

Based on CGI's past experience, 99% of service calls are due to incomplete or incorrect installation. If you are experiencing leaks or difficulty locking the doors, please check the following items.

1. If you are experiencing leaks under the door sills (or sidelites), Make sure that sealant has been applied:
  - At door sill extrusion between sill and jambs (see Item 1 at Figure 1, page 10)
  - At ends of Sill gutter, where it meets the jamb (see Item 3 at Figure 1, page 10)
  - To heads of all sill installation fasteners . Also make sure that door is closing properly, and that the weatherstripping is making good contact (refer to items 3 & 6 below).
2. Carefully check the perimeter caulking/seals between the door and surrounding structure. Improper caulking will create leaks at any point along the door frame and due to gravity, the water will show up at the bottom or sill of the door.
3. Make sure the door panels do not rub against the pile weatherstripping at the head and sill. If they do, they will tear up the weatherstripping. Once this happens, you will lose the effectiveness of the weatherstripping. Also check and make sure that there is no missing or damages weatherstripping at any point.
4. If the leak is in an *in-swing* door, check that the weep system at the sill is free from obstructions, and that the foam tape is correctly placed along the sill. Inspect the foam tape from the outside with the door closed; there should not be any gaps between the tape and the door panel. Remember *in-swing* doors are only rated to 7.5 PSF of water and cannot be compared to the water resistance of a standard CGI *out-swing* door.
5. Look at the door from the outside. Is the distance between the door panel and frame (at top and bottom) even, or does it seem to vary from one end of the panel to the other. Improperly installed units will create excessive gaps in the weatherstripping that will cause leaks.
6. Standing outside, open and slowly close the active panel. As the panel approaches the closing position, do you see a uniform edge distance (top to bottom) between the active and inactive panels? If you do not see an even gap, the frame is racked and will need to be re-installed or corrected. Also look at the gap between the astragal and the inactive panel (still from the outside). If you see an uneven gap, you do not have proper weatherstripping contact and the locks may not work correctly. Correcting the frame installation will resolve this problem.



7. Open the active panel and disengage the flush bolt on the inactive panel. Does the inactive panel appear to want to bulge out at either the top or the bottom? If it does, the frame is racked and will need to be re-installed or corrected. This problem causes the locks not to work properly.
8. When you close the door, does the active panel latch easily onto the inactive panel or do you have to push the panel to latch the door? If it is difficult to latch the door, adjust the latch strike that is located on the frame (single doors) or inactive panel (pair of doors) opposite the lever.
9. Open the active panel and activate the three point lock by turning the thumb turn. Note the travel (turning motion) that the thumb turn makes with the door open. Now close the door and activate the three point lock again by turning the thumb turn. Does it seem to have the same travel as when opened or does it appear to hit something. If you think it is not engaging completely, pull on the lever slightly while you turn the thumb turn. If it feels that this works better, then you may need to slightly file the holes at the head and sill where the three point deadbolts engage into or simply remember to pull on the lever when locking the door. The three point lock can work on a door that is slightly racked by slightly filing the holes.
10. When a door is incorrectly installed and someone tries repeatedly to lock the door, the top and bottom locks in the three point lock mechanism may loose adjustment. To check the three point locks, open the active panel and activate the three point lock until it “clicks” on the locked position. Now try to retract the deadbolts at the top and bottom of the panel with your fingers. The deadbolts should not retract into the panel. If they do retract, adjustment is required. The adjustment is made by turning the adjustment screw located about 4 inches inside the stile. This screw is visible when looking into the door stile from each end. . Tighten the screw (turn clockwise) one half turn at a time and recheck the deadbolt by unlocking and re-locking. Repeat this step until the deadbolt stays in the locked position. Once it stays locked, turn the screw an additional half turn. **DO NOT OVER TIGHTEN THE SCREW.** This could cause the top or bottom lock to remain engaged when you try to unlock the door.

